

ASSEMBLY INSTRUCTIONS

COMPACTFLAT SN 2 PLUS longside

VERSION: 02

SPRACHE: ENGLISH | ORIGINAL ASSEMBLY INSTRUCTION

IMPORTANT! READ CAREFULLY BEFORE INSTALLATION!



LEGAL NOTICE

Subject to changes due to technical improvements. These assembly instructions correspond to the technical status of the delivered product and not to the current development status at the manufacturer. If pages or parts of the assembly instructions are missing, please contact the manufacturer's address given below. The original language of these assembly instructions is German. Any assembly instructions in another language are a translation of the assembly instructions in German. The assembly instructions are protected by copyright. Without the written permission of AEROCOMPACT® Services GmbH, the assembly instructions may not be copied, reproduced, microfilmed, translated or converted for storage and processing in EDP systems, either in part or in full.

Copyright by AEROCOMPACT® Services GmbH

MANUFACTURER

AEROCOMPACT® Services GmbH
Gewerbestrasse 14
6822 Satteins
Austria

office@aerocompact.com
www.aerocompact.com

UPDATE

This manual is subject to change without notice. This does not represent any obligation on the part of the manufacturer.

CREATION DATE

04/2023

TOC

General	4
Information about this manual	4
Applicable Documents	4
Explanation of Symbols	4
Limitation of liability	5
Safety	6
Appropriate use	6
Requirements of personnel	6
Working safely	6
Breakthrough protection	6
Personal protective equipment (PPE)	6
System overview SN 2 Plus 10°	8
System overview SN 2 Plus 5°	10
Accessories for ballasting	12
Accessories	12
Roof Anchor Attachments	13
Assembly	14
Measure the area	14
Attach additional building protection mats (optional)	14
Attach construction protection mats to cut-to-size base rails	15
Foot mounting	16
Connecting the base rails	16
Attaching the feet	16
Building protection mats for level compensation (optional)	17
Mounting ballast	18
Mount ballast with ballast clamp	18
Cross-members	19
Possible mounting positions of the cross-members	19
Mounting the cross-member with preassembled option	19
Connect module rows	20
Secure ballast with cross-members	21
Installing the modules	21
Attaching the microinverter (optional)	24
Mount double point anchor attachment	24
Connect system with anchor attachments	24
Mount single roof anchor attachments	25
Connect system with single roof anchor	25
Maintenance, demounting and disposal	27
Maintenance	27
Dismantling	27
Disposal	27

GENERAL

INFORMATION ABOUT THIS MANUAL

These installation instructions describe the procedure for installing the product. Read these assembly instructions carefully before starting the assembly. The personnel must have carefully read and understood these instructions before starting any work. The basic prerequisite for safe working is compliance with all the safety notes and instructions for action given in this manual. In addition, the local accident prevention regulations and general safety regulations for the product's area of application apply. Illustrations in this manual are for basic understanding and may differ from the actual design.

APPLICABLE DOCUMENTS

In addition to this manual, you have received the following documents. Always comply with the instructions and notes contained.

- Project report from AEROTOOL
- Planning documents and drawings

EXPLANATION OF SYMBOLS

SYMBOLS FOR INSTRUCTIONS



Prerequisites for action instruction



Results of action steps



Step by step action instruction



This note provides useful information for proper assembly

SYMBOLS IN ILLUSTRATIONS -ACTIVITIES



Check AEROTOOL planning documents



Activity by hand



Optional component,
optional installation method



Visual inspection



Observe right angle

SYMBOLS IN ILLUSTRATIONS - TOOLS



Measuring tape, measure



Pencil, mark



Chalk line



Scissors, tin snips, cut to size



Cordless screwdriver, screwdriver



Use a torque wrench,
Observe torque



Use Allen key

LIMITATION OF LIABILITY

All information and notes in these instructions have been compiled taking into account the applicable standards and regulations, the state of the art and our many years of knowledge and experience. The manufacturer accepts no liability for damage in the following cases:

- Non-compliance with these instructions and the relevant planning documents
- Use deviating from the intended use
- Use of insufficiently qualified personnel
- unauthorized modifications
- technical changes
- Use of non-approved spare parts

The actual scope of delivery may differ from the explanations and illustrations described here in the case of special versions, the use of additional ordering options or due to the latest technical changes. These assembly instructions and the project report supplied with the product are integral parts of the product. The information, data and instructions given in the assembly instructions were up to date at the time of printing. No claims can be made for products already delivered that deviate from the information, illustrations and descriptions. The project report supplied with the system contains the static/structural calculation related to the location. Follow the position of the modules on the roof, the number and position of the building protection pads and the ballast distribution exactly according to the project report. If the module layout on the roof changes due to local conditions, e.g. unforeseen interference areas, the structural analysis must be recalculated. Aero-compact GmbH is not responsible for the project-related statics of the roof structure, for obtaining and documenting the consent of the roof manufacturer for the installation of the corresponding fasteners on the respective roof, or for the professional execution.

The installation instructions of the module manufacturers must be observed. Es erfolgt keine Prüfung durch AEROCOMPACT® Services GmbH bezüglich Baubarkeit oder Montagerichtlinien. Bei Nichteinhaltung behält sich AEROCOMPACT® Services GmbH den Haftungsausschluss vor. For a system with a clamp on the short side of the module, it is assumed that the module may also be used with this installation method (clamp on the short sides of the module). This approval can either be generally available as part of the module certification or, under certain circumstances, can also be given by the module manufacturer on a project-specific basis.

SAFETY

This section provides an overview of all important safety aspects for the protection of persons.

APPROPRIATE USE

The CompactFLAT flat roof system is designed exclusively for installing PV modules on flat roofs or similar flat surfaces. The system must be properly installed in accordance with these installation instructions. PV modules used with the CompactFLAT system should be approved by the module manufacturer. AEROCOMPACT accepts no liability for loss of performance or damage of any kind to the PV modules. Any other use of the CompactFLAT system is considered improper.

REQUIREMENTS OF PERSONNEL

Systems may only be installed and commissioned by persons who, due to their technical qualification or experience, can guarantee that they are carried out in accordance with the regulations. National and site-specific building codes, standards and environmental protection must be strictly adhered to. Under no circumstances must the installation personnel be under the influence of medication, alcohol or drugs. Personnel who are in training must only carry out work under the supervision of qualified personnel who are authorized to train personnel.

WORKING SAFELY

The assembly personnel to be carried out are responsible for ensuring that the local regulations on occupational safety and accident prevention are complied with. Areas below the roof on which work is being carried out must be protected from any falling objects. Where this does not succeed, affected areas must be closed to the public.

In case of unsuitable weather conditions, work on the roof must not be continued any longer than necessary - or not started at all. Never carry out assembly work in strong winds. Strong wind exerts enormous forces on the large-area PV modules. There is a risk that a module could be torn off the roof and people could be injured. Never work in wet conditions or at temperatures below the freezing point. Depending on the roof pitch there is a risk of slipping.

Only use suitable, intact and tested ladders. Set up and secure ladders according to instructions. Separate rules apply to mechanical climbing aids (lifts, lifting platforms, ...). Never use the PV mounting system as a climbing aid. Keep sufficient distance from overhead electrical lines. Equipotential bonding between the individual system parts must be carried out in accordance with the respective country-specific regulations. When cutting materials, make sure that there are no burrs, especially at edges and corners, as there is a risk of injury.

BREAKTHROUGH PROTECTION

Skylights, skylights, large vents, etc. usually cannot withstand the weight or impact of a person. Such objects must be secured in a similar way as the edge of the roof. Corrugated fibre cement roofs can be prone to breakthrough over the entire surface. Define walking routes and secure them with load distribution measures. On roofing or roof structures that do not have sufficient load-bearing capacity (e.g. thin sheets, corrugated fibre cement), always work with load distribution aids.

PERSONAL PROTECTIVE EQUIPMENT (PPE)

The purpose of personal protective equipment is to protect people from health and safety hazards at work. Personnel must wear personal protective equipment during assembly. Personal protective equipment is explained below:



Wear protective goggles when drilling.



Wear cut-resistant work gloves during assembly.



Wear safety boots.



Use fall protection.



Helmets are required for all persons involved on the construction site.

SYSTEM OVERVIEW SN 2 PLUS 10°

CLAMPING TYPE: LONG-SIDE CLAMPING
DESIGN: CONNECTED BASE RAILS

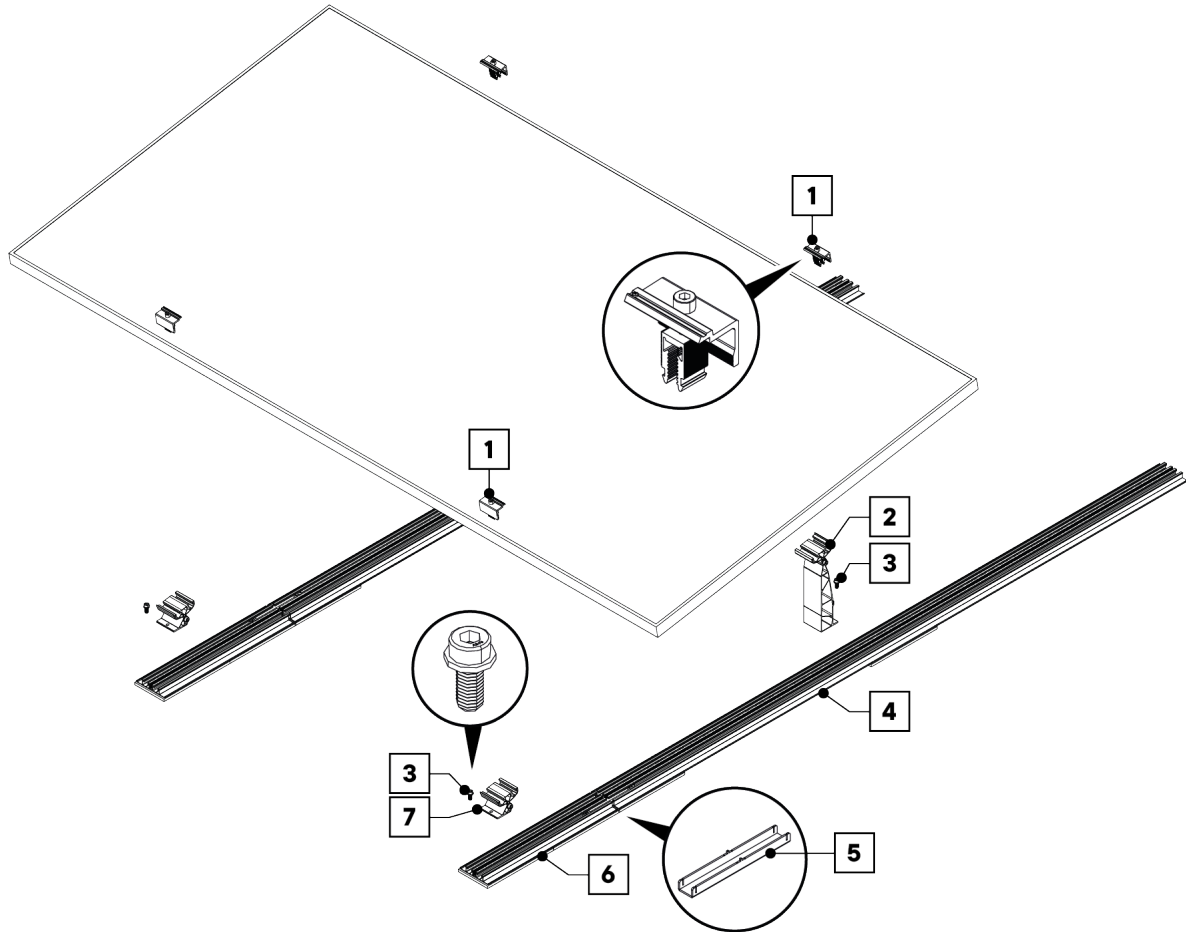

- 1 End clamp | CLE20
- 2 SN Rear Bracket Landscape 10° | SNLS10RB
- 3 Allen screw M8x18 with tothing | AB8x18S
- 4 Base rail 1980 mm | BR1980
- 5 SN base rail connector | BRCNSN
- 6 Base rail 450 mm | BR450
- 7 SN Front Bracket Landscape | SNLSFB

CLAMPING TYPE: LONG-SIDE CLAMPING
DESIGN: LONG BASE RAILS

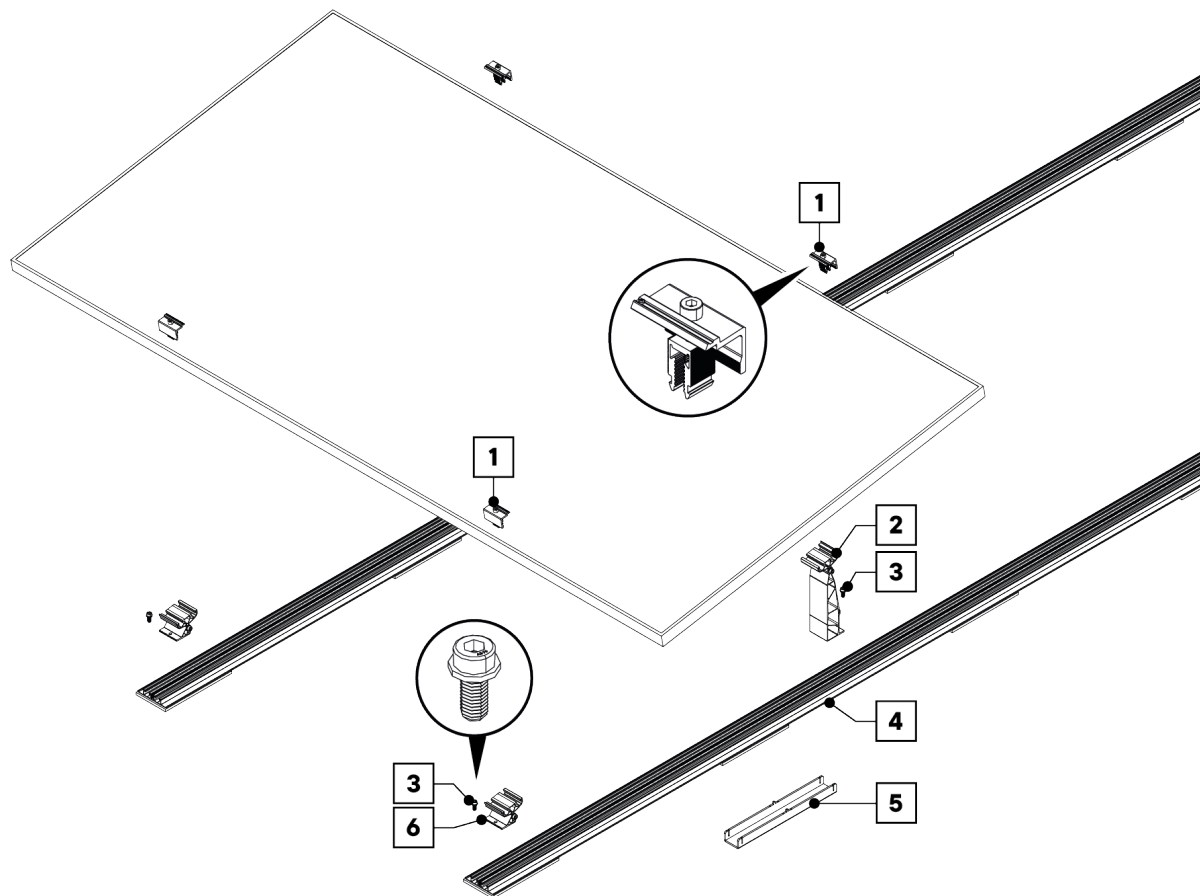

- 1 End clamp | CLE20
- 2 SN Rear Bracket Landscape 10° | SNLS10RB
- 3 Allen screw M8x18 with tothing | AB8x18S
- 4 Basisschiene 5800 mm | BR5800
- 5 SN base rail connector | BRCNSN (optional)
- 6 SN Front Bracket Landscape | SNLSFB

SYSTEM OVERVIEW SN 2 PLUS 5°

CLAMPING TYPE: LONG-SIDE CLAMPING
DESIGN: CONNECTED BASE RAILS

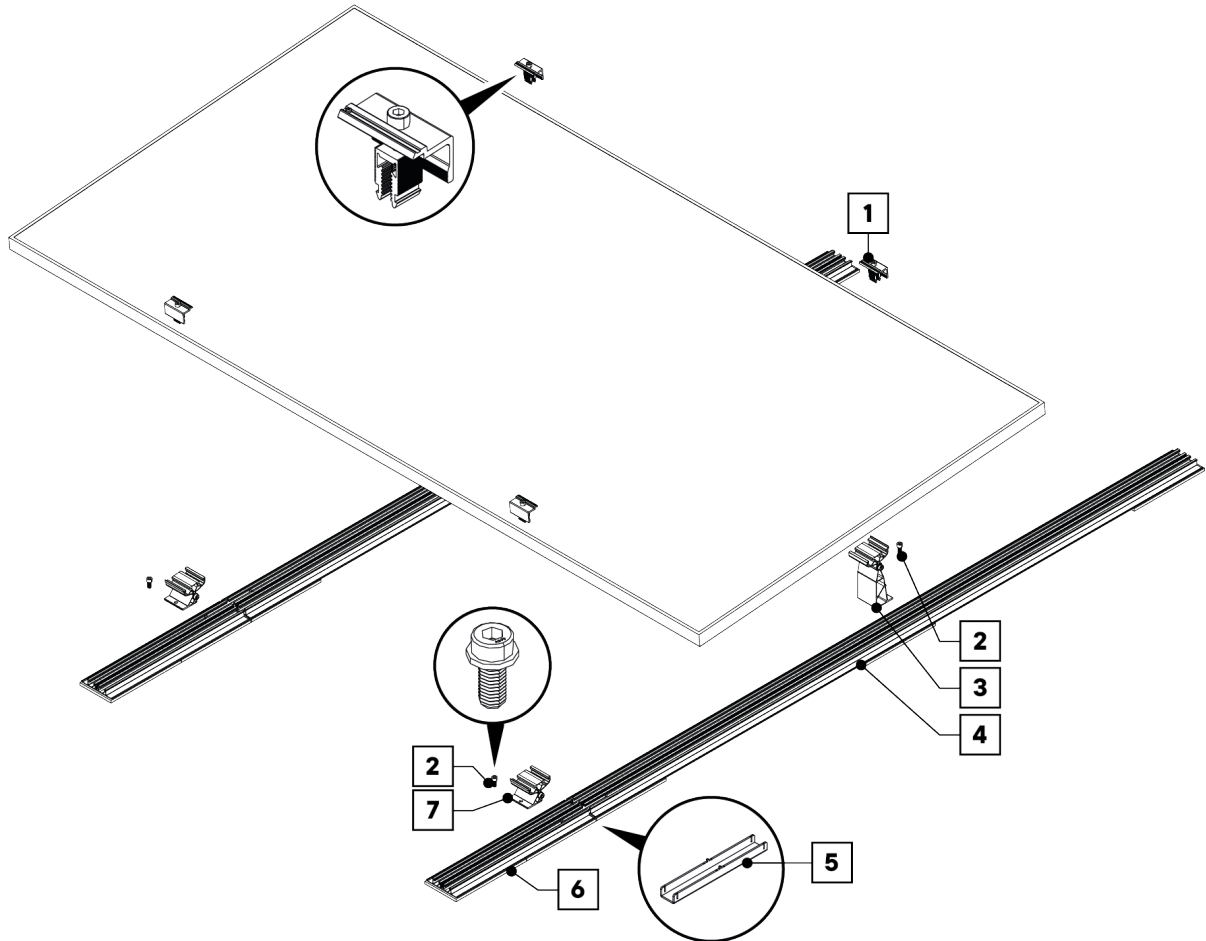

- 1 End clamp | CLE20
- 2 Allen screw M8x18 with tothing | AB8x18S
- 3 SN Rear Bracket Landscape 5° | SNLS5RB
- 4 Base rail 1980 mm | BR1980
- 5 SN base rail connector | BRCNSN
- 6 Base rail 450 mm | BR450
- 7 SN Front Bracket Landscape | SNLSFB

CLAMPING TYPE: LONG-SIDE CLAMPING
DESIGN: LONG BASE RAILS

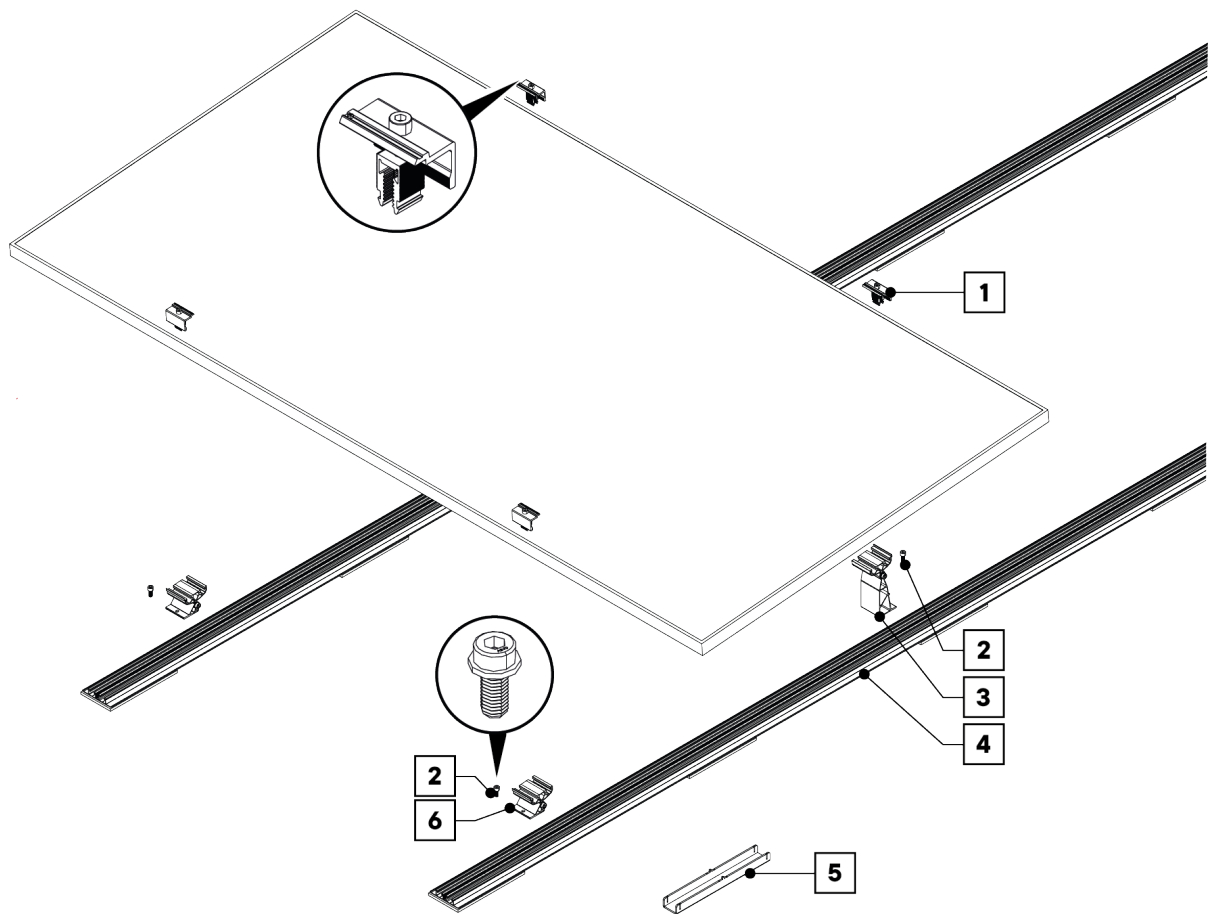

- 1** End clamp | CLE20
- 2** Allen screw M8x18 with tothing | AB8x18S
- 3** SN Rear Bracket Landscape 5° | SNLS5RB
- 4** Basisschiene 5800 mm | BR5800
- 5** SN base rail connector | BRCNSN (optional)
- 6** SN Front Bracket Landscape | SNLSFB

ACCESSORIES FOR BALLASTING

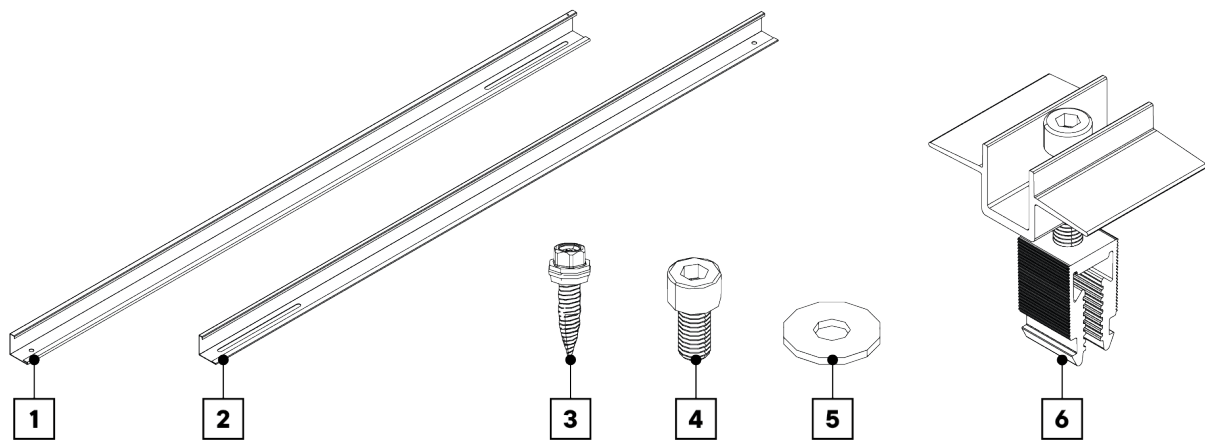

- 1 Cross strut, inner part 990 mm / 38.98 inch, 1150 mm / 45.28 inch, 1290 mm / 50.79 inch | CSi990, CSi1150, CSi1290
 - 2 Cross strut, outer part 990 mm / 38.98 inch, 1150 mm / 45.28 inch, 1290 mm / 50.79 inch | CSo990, CSo1150, CSo1290
 - 3 Thin sheet metal screw 6x25 | MSS6x25
 - 4 Allen screw M8x18 with tothing | AB8x18S
 - 5 Washer 8.4x24 | FW8.4/24
 - 6 Ballast clamp | CLB10
-

ACCESSORIES

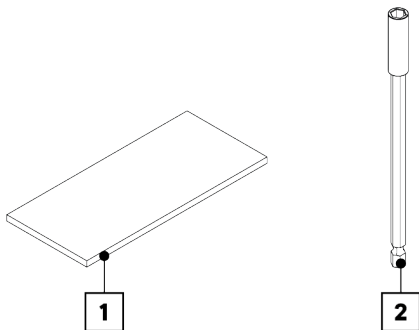

- 1 Protection pad 200 x 102 | PP200/102
 - 2 Bit Extender 150 mm / 5.91 inch | BIT150E
-

ROOF ANCHOR ATTACHMENTS

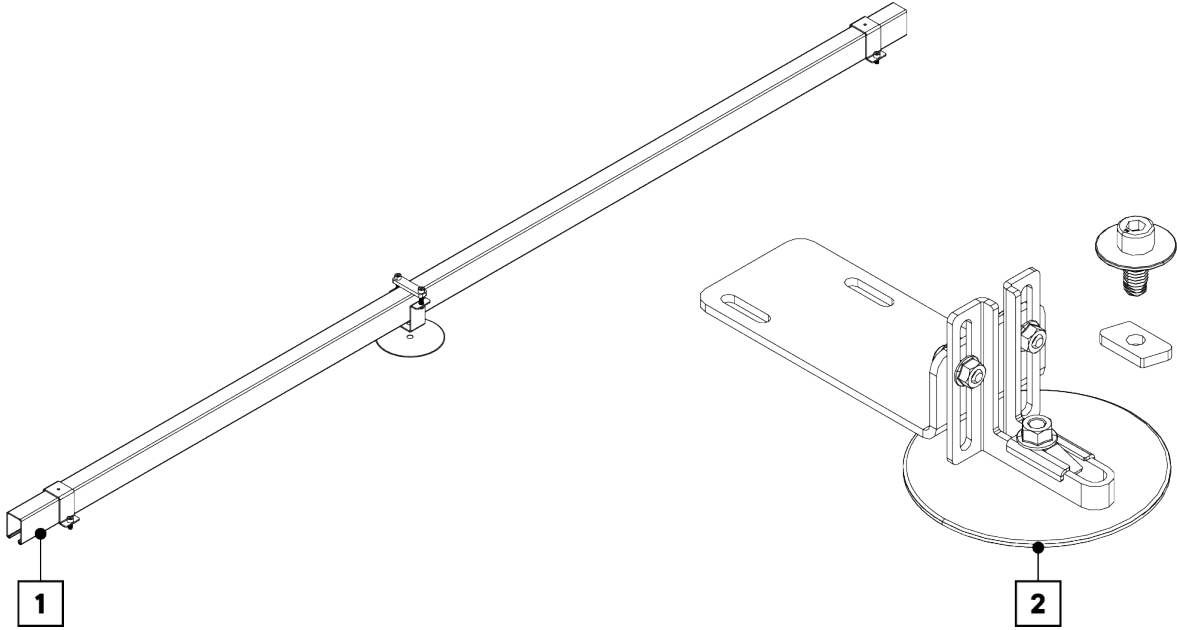

- 1 Double point anchor connection with anchor rail 1280 mm or 2500 | DAPA, AR1280, AR2500
- 2 Single roof anchor connection for SN | APA-SN

ASSEMBLY

MEASURE THE AREA

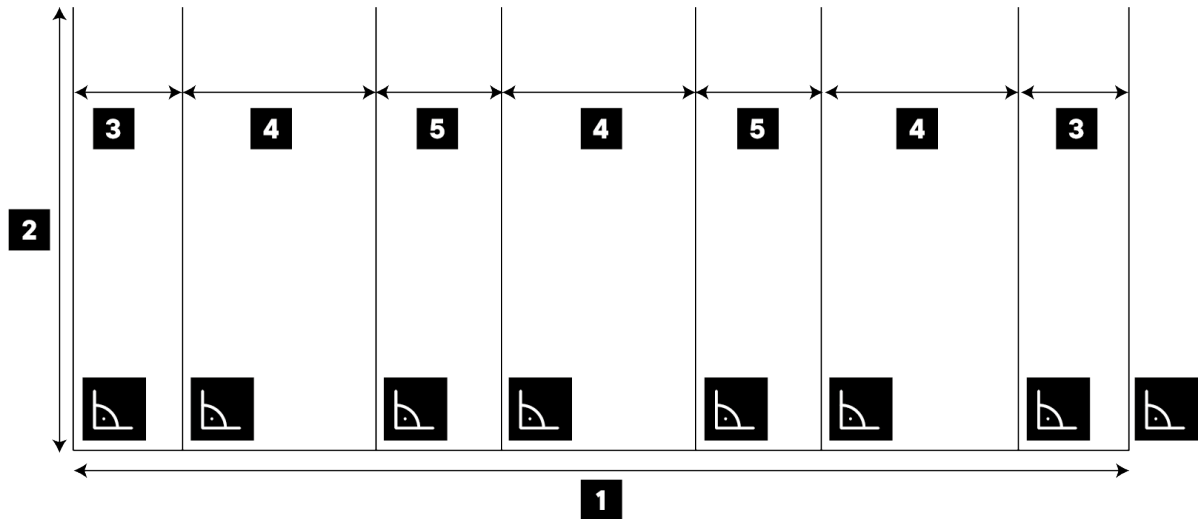

- Take the dimensions of the array field from the planning documents.
- Determine the positions of the rails:
- Measure the length of the module field and mark the line.
- Measure the width of the array and mark the line.
- Determine distance (3), (4) and (5) according to the following:

Distance (3) according to the recommendation of the module manufacturer's clamping position, if permissible 1/4 of the module length.

Distance (4) according to the recommendation of the module manufacturer's clamping position, if permissible 1/2 of the module length.

Distance (5) according to the recommendation of the module manufacturer's clamping position, if permissible 1/2 of the module length + 20mm

- Measure distances (3), (4) and (5) and mark lines.

ATTACH ADDITIONAL BUILDING PROTECTION MATS (OPTIONAL)

Depending on the structural situation, the support surface of the system must be improved. For this purpose, additional building protection mats are attached.

- i** Remove the number of additional building protection mats required from the planning documents. The building protection mats can be pre-assembled.

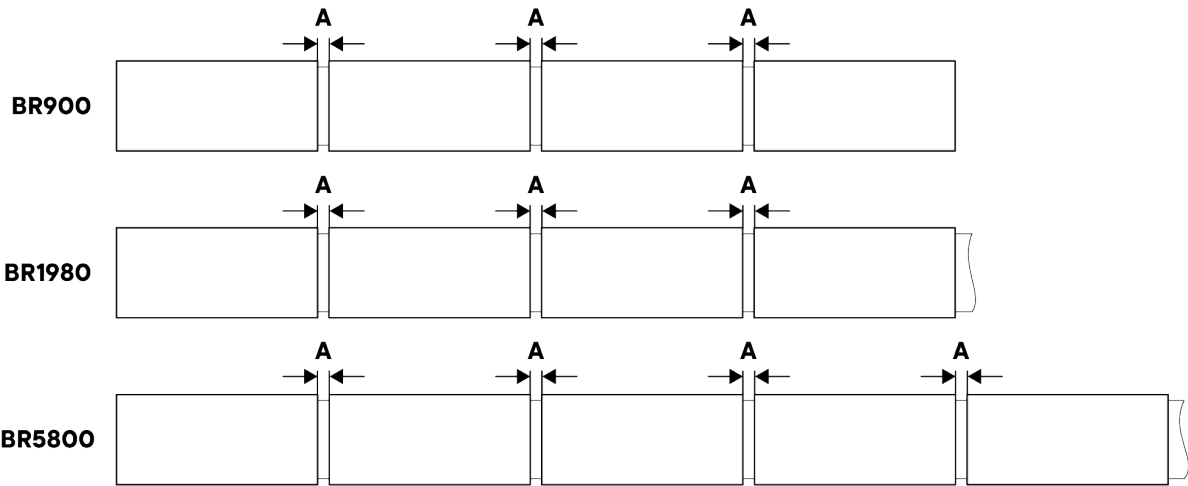

- ☑ Make sure that the base rails are dry and free of grease, dust or other dirt.
- ☑ Depending on the length of the base rails, install the following number of building protection mats:
 - BR900 Two additional protection pads per rail
 - BR1980 Two additional protection pads each between the existing protection pads
 - BR5800 Three additional protection pads each between the existing protection pads
- ☑ Make sure that the distance (A) between the building protection pads is uniform.

Attach construction protection mats to cut-to-size base rails

The base rails (BR5800) can be cut/separated for the following reasons:

- Thermal separation (compare with planning documents)
- Base rails protrude beyond the module field.

i To protect the roof cladding, protection pads are placed at the separation points below the base rails. If there is a protection pad at the separation point, it will be removed.



CAUTION!

Danger of injury due to sharp edges!

- ☑ Wear gloves when removing the existing protection pad.
- ☑ Handle carefully.

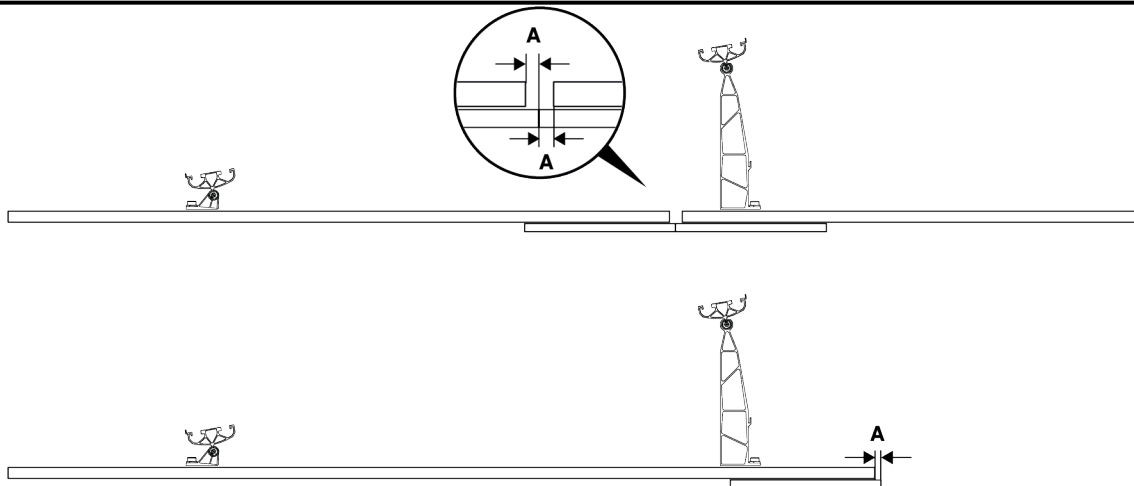



- Remove metal burrs from the cut.
- Attach protection pads on the end of the base rails.
Overlap of the building protection mats in each case A = 7mm or 1/4 inch.

FOOT MOUNTING

Connecting the base rails

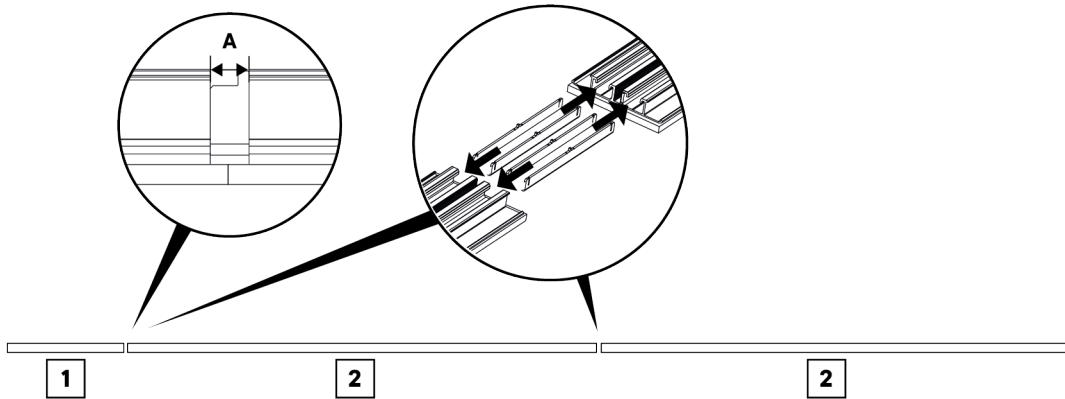

- Line up the base rails (1 and 2) according to the planning documents.
- Insert a base rail connector at each joint area (see illustration).
- ✓ Distance A = 7 mm.

Attaching the feet

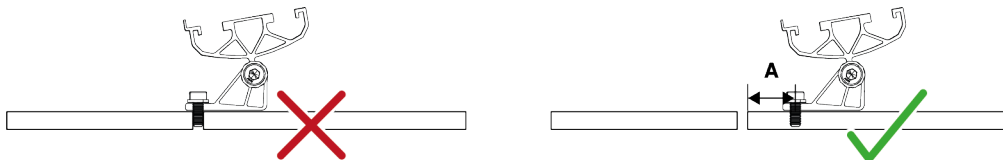

- ⓘ If base rails are connected, make sure that the brackets are never screwed in the joint area between two base rails.
Distance A from the edge of the base rail to the screw min. 20 mm or 3/4 "

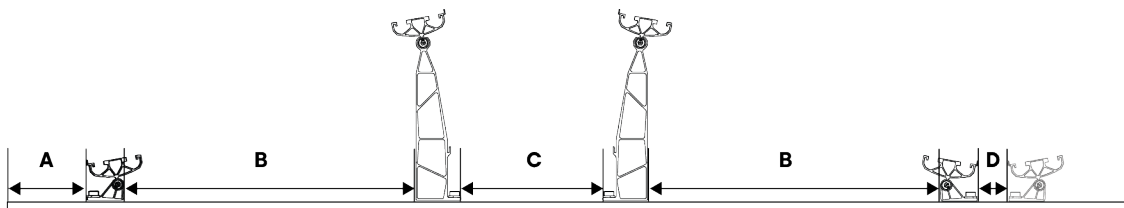

➤ Dimensions A, B, C and D can be taken from the associated planning documents.

ⓘ Never use an impact or impulse screwdriver when assembling the components. For smooth assembly, use a cordless screwdriver with a bit extension (length = min. 150 mm).

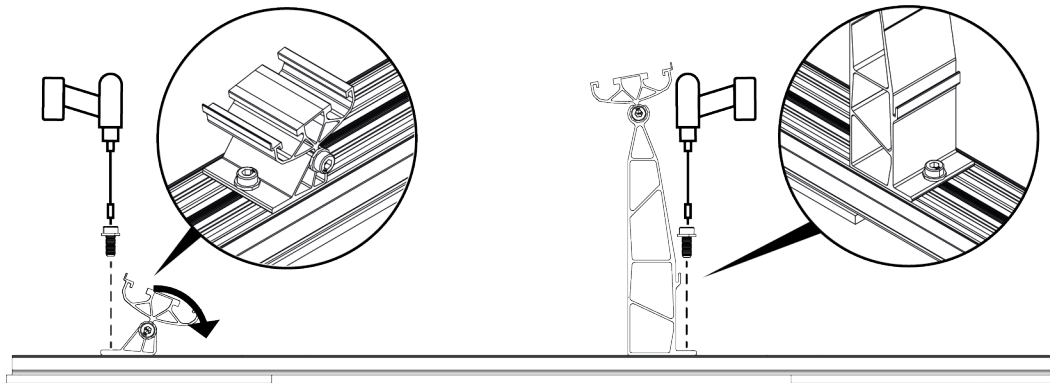

- To simplify installation, tilt the foot rocker backwards as shown in the illustration.
- Position the feet at the determined positions on the base rail and screw them tight with Allen screws (AB8x18S).
- Tighten the Allen screws to 10 Nm.

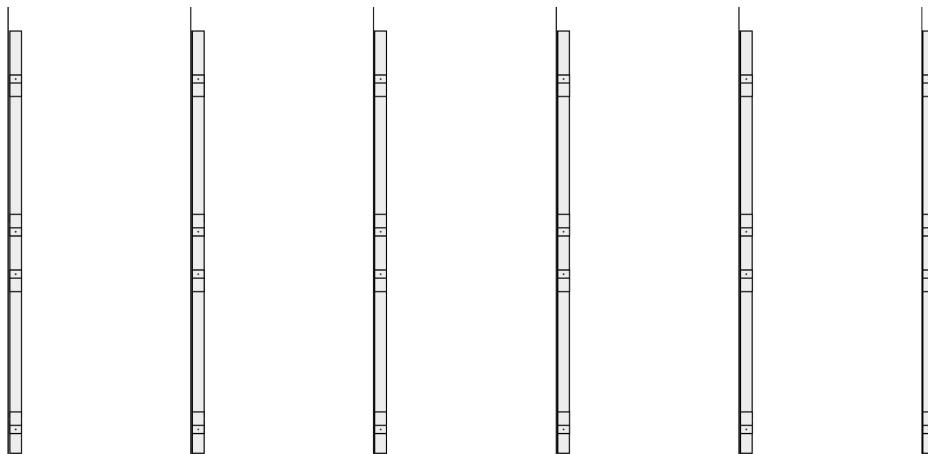

➤ Align the pre-assembled base rails at the marked positions according to the planning documents.

BUILDING PROTECTION MATS FOR LEVEL COMPENSATION (OPTIONAL)

ⓘ In the event of unevenness, additional building protection mats are placed underneath for level compensation.

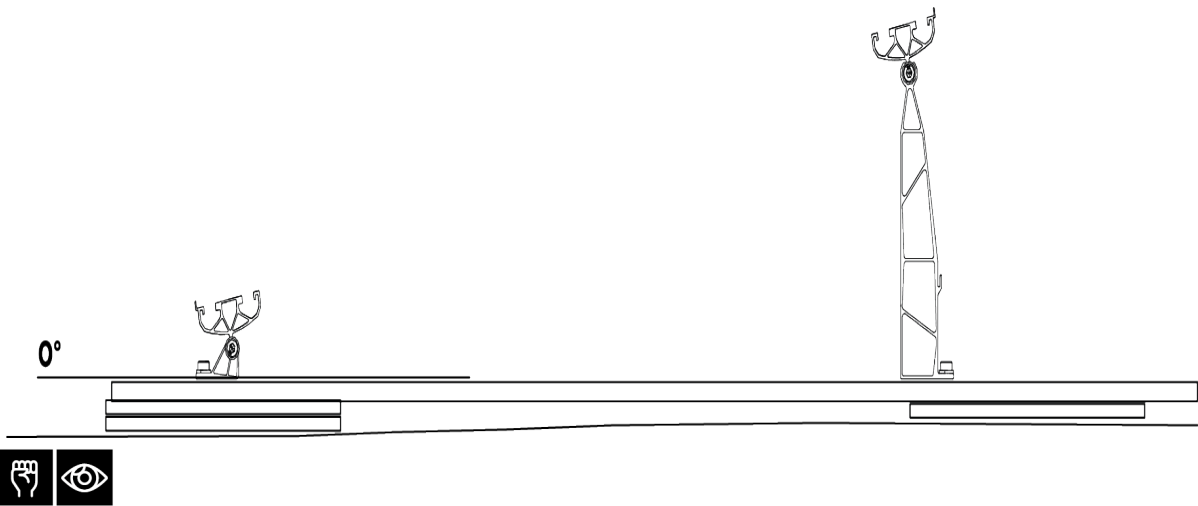

▶ Install additional building protection pads below the bonded building protection mats as required.

MOUNTING BALLAST

i Depending on the circumstances, the system can be ballasted in various ways. The exact number and position of ballasts are specified in the planning documents.

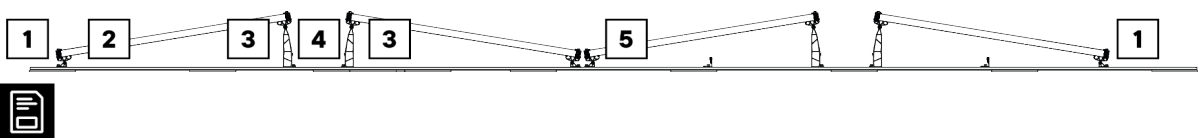

The ballast can be mounted at the following positions:

- (1) in front of the module (east/west-side)
- (2) under the module (modul-mountain)
- (3) under the module (module mountain)
- (4) behind the module
- (5) behind the module (module valley)

Mount ballast with ballast clamp

i With the ballast clamp, 1 - 3 ballast blocks can be attached to the base rail.

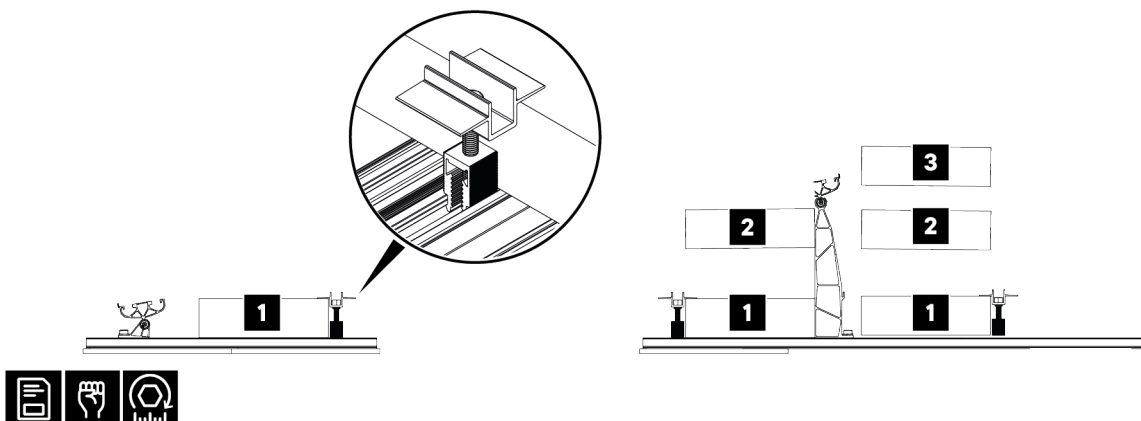

- Attach the ballast clamp to the base rail.
- Place the ballast stone (1) on the base rail as close as possible to the respective bracket.
- Place the ballast stone (2).
- Fix the ballast clamp in place: Tighten the screw until the wings of the ballast clamp are flush with the ballast stones.
- Attach ballast stones (3) and (4).

CROSS-MEMBERS

- i** Depending on the planning variant, the cross-members are used for the following purposes:
- Connection of the base rails with pre-assembled option
 - Connection of the module rows
 - Fix ballast

Possible mounting positions of the cross-members

- i** The position and number of cross-members in the module field can be seen in the planning documents.

L Cross-member is used to fix ballast

L Cross-member is used for joining, connecting the base rails and/or fixing the ballast

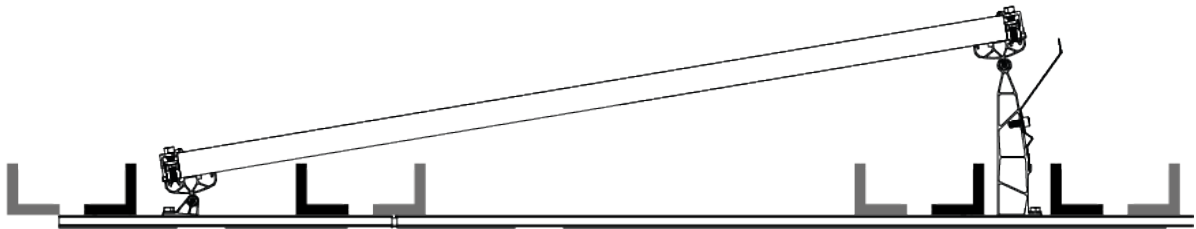

Mounting the cross-member with preassembled option

- i** The preassembled option is only possible for connected and long base rails.

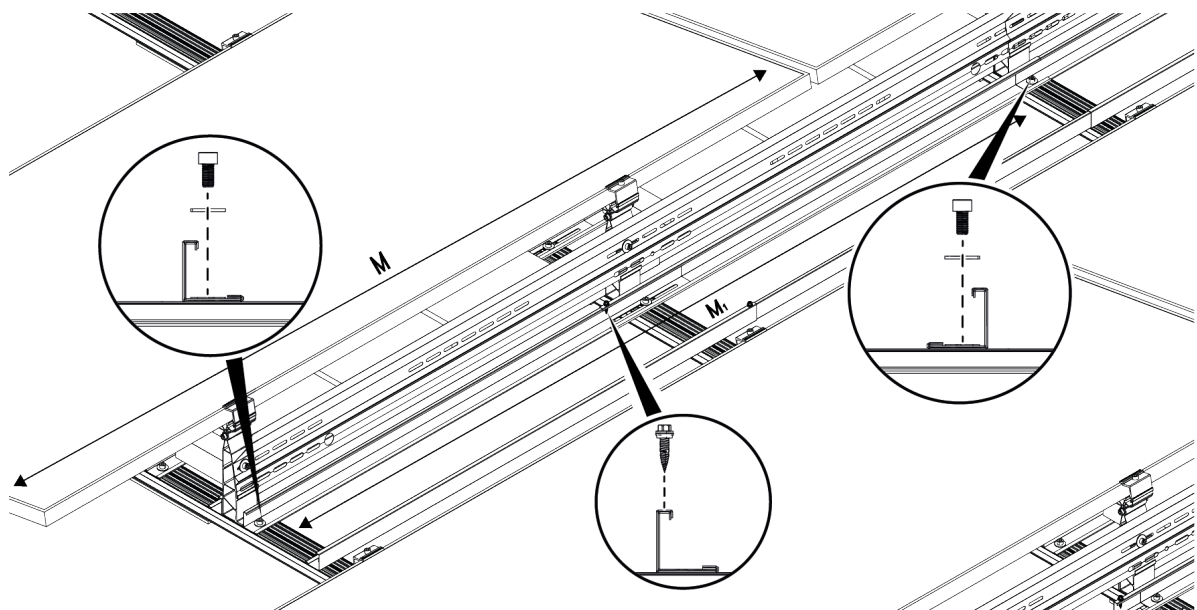

- ▶ Slide the outer part and inner part of the cross-members into each other.
- ▶ Determine dimension M = module length.
Dimension M_1 = module length + 20 mm
- ▶ On the cross-members, measure the dimension M_1 from the center of the bore.
- ▶ Connect the inner part and outer part of the cross-members with a thin sheet metal screw.
- ▶ Screw the cross-member with Allen screw (AB8x18S) and washer to the base rail.

Connect module rows

- i** In order to obtain a connection between the module rows, cross-member outer parts are used. The exact number and position of the connections with the cross-members can be found in the planning documents.

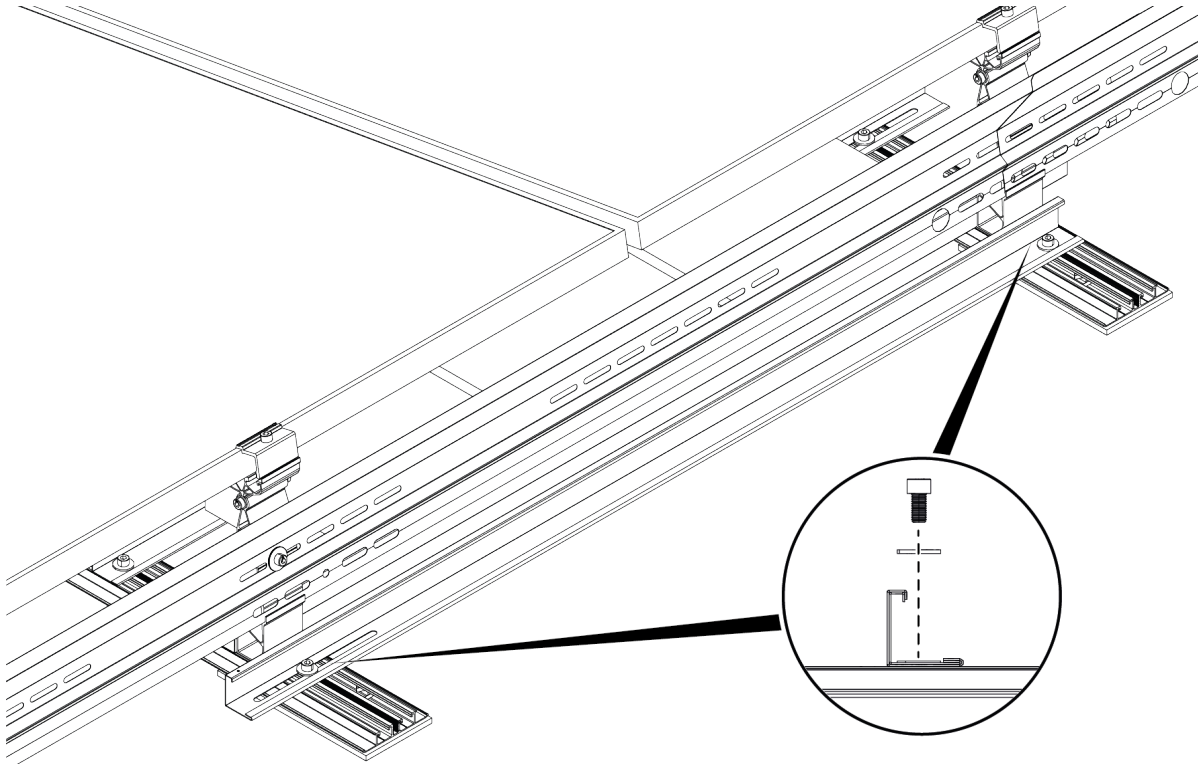

- ▶ Attach an outer cross-member to the rear feet between the module rows.
- ▶ Make sure that the distance of 2 cm between the modules is maintained.
- ▶ Screw the cross-member with Allen screw (AB8x18S) and washer to the base rail.

Secure ballast with cross-members

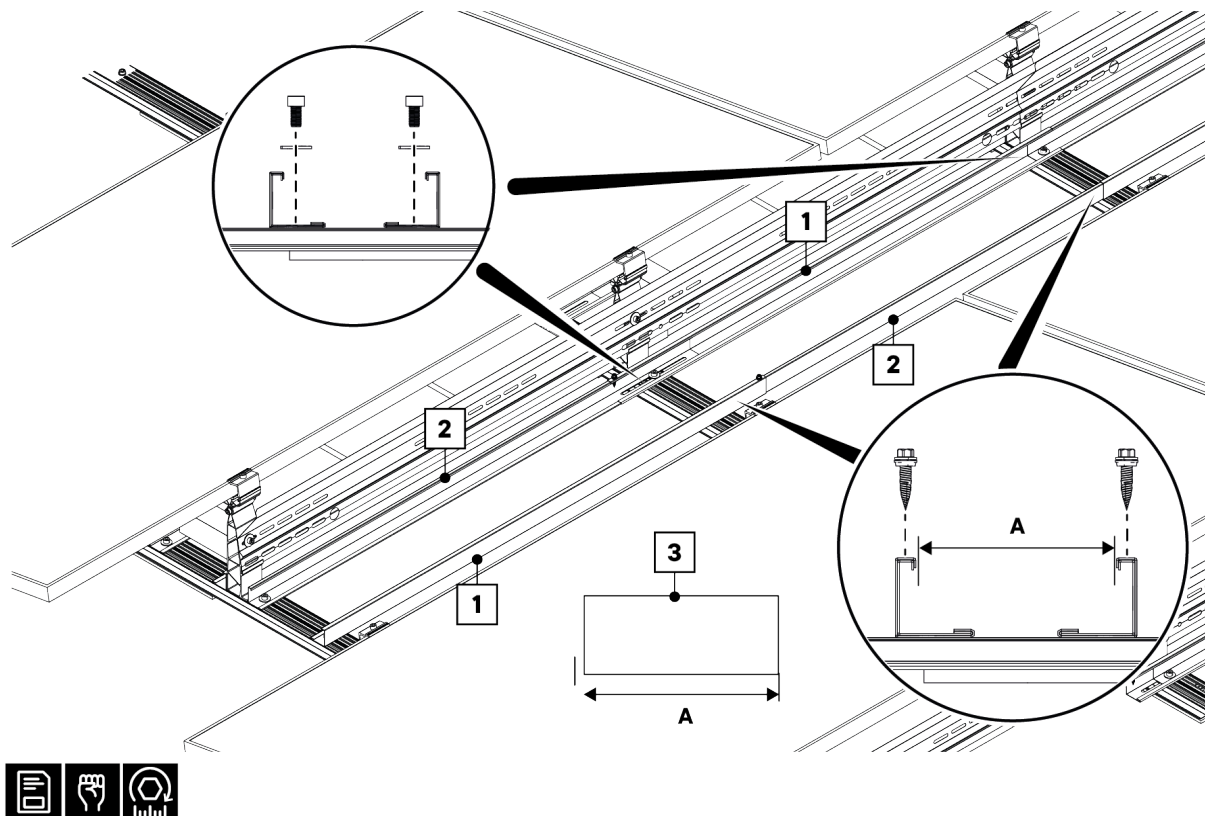

- ▶ Use the outer part (1) and inner part (2) of the cross struts alternately and push them into each other.
- ▶ Position the cross-members flush with the base rail at the outer edge of the module field.
- ▶ Screw the cross-members with an Allen screw (AB8x18S) and washer to the base rail.
- ▶ Tighten the screws to 10 Nm with a torque wrench.
- ▶ Screw the cross-members at each point of overlap with oblong holes with a thin sheet metal screw.

i If the ballast rails overlap at a point where there is no base rail, the ballast rails are only connected to the sheet metal screws.

INSTALLING THE MODULES

i Depending on the planning of the system, the ballast is mounted in front of the modules. Start mounting the modules in the southern row.



- ▶ Attach an end clamp to the front bracket in the outer clamping channel.

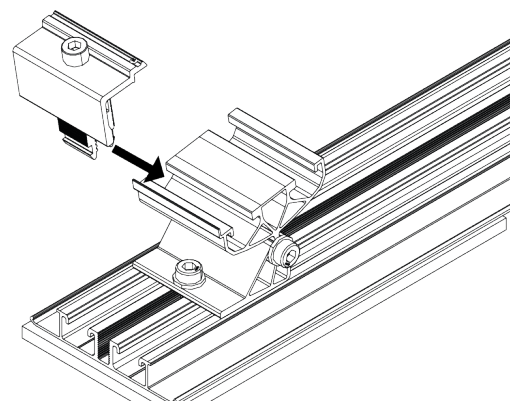

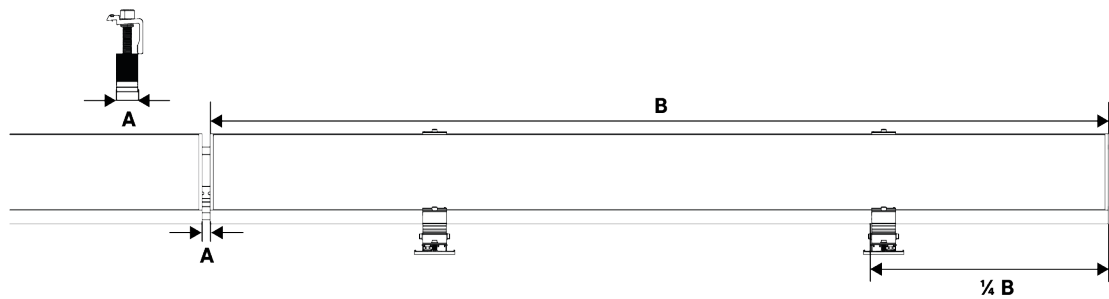
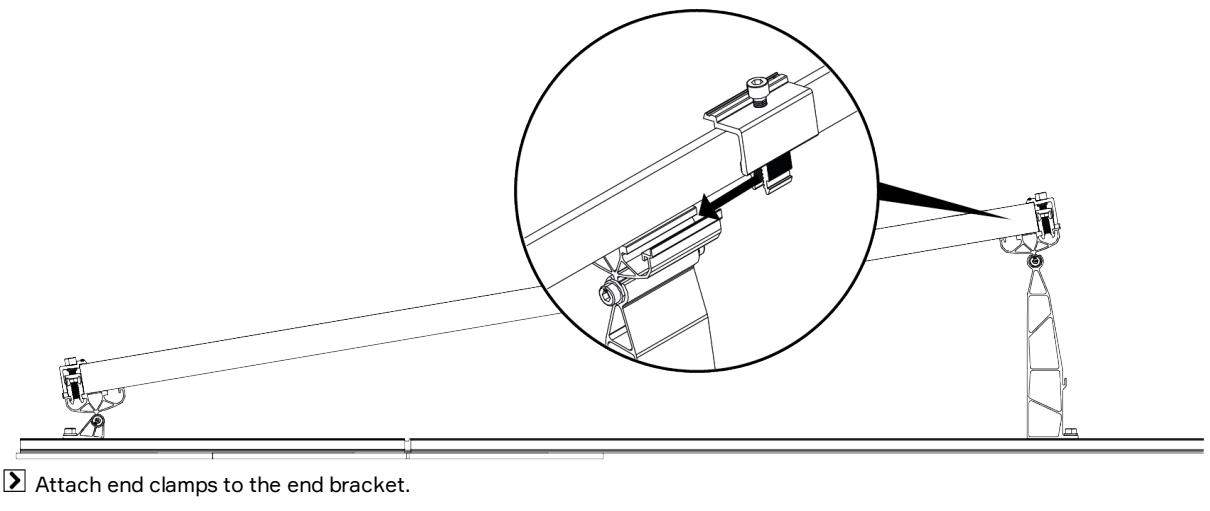
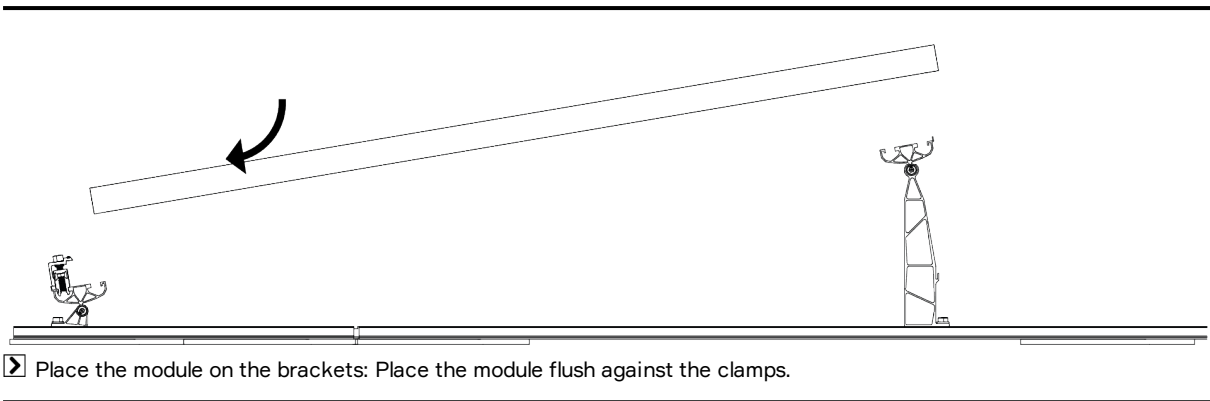

i The distance (A) between the modules is 2 cm. As an aid 2 clamps can be used as gauges.
 Clamp position: according to the module manufacturer's clamp position recommendation, if permissible 1/4 of the module length B, measured from the respective module edge.



- Continue mounting the modules row by row.
- Align the rail lines as required.

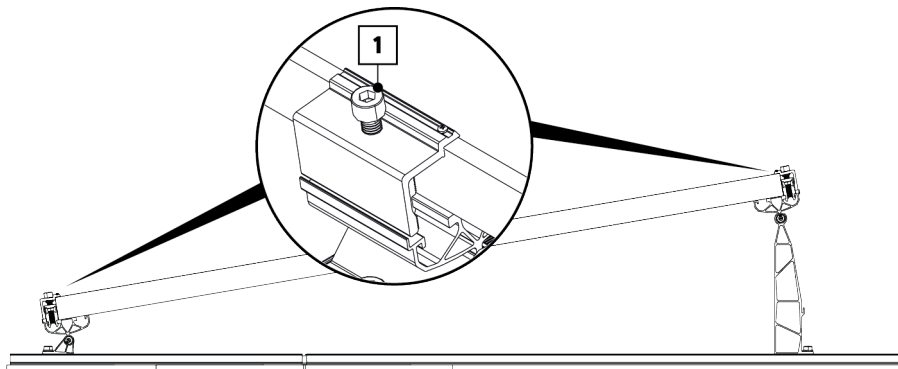
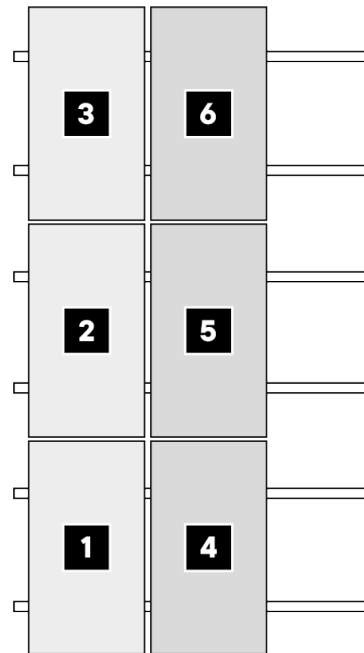

- Tighten the screws at the end terminals with 15 Nm or 11 ft lb each.

REPOSITION / REPLACE CLAMPS

- Demount clamp: Unscrew the screw at the clamp completely.
- Depending on the mounting situation, squeeze the clamp laterally and pull it out or pull it laterally out of the rail.

ATTACHING THE MICROINVERTER (OPTIONAL)

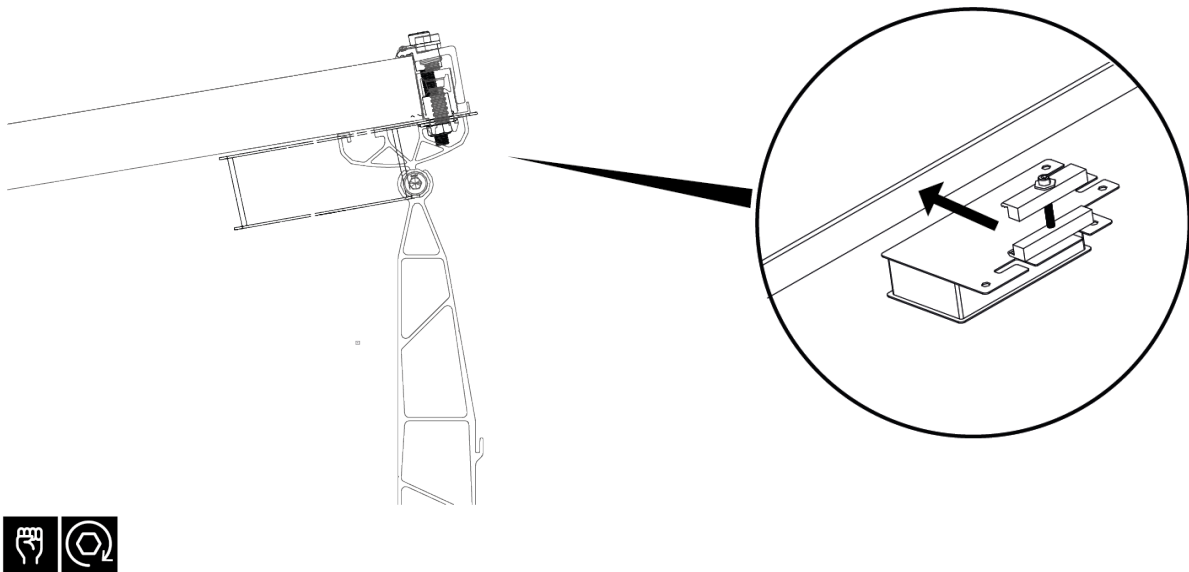

- Mount the Microinverter on the module according to the module manufacturer's specifications.

MOUNT DOUBLE POINT ANCHOR ATTACHMENT

i The anchor attachments must be provided by the customer and are not included in the scope of delivery of AEROCOMPACT. For the installation of the roof anchor connection, the roof anchors must be equipped by the customer with a threaded rod with a maximum size of M12 (7/16 inch). Refer to the AEROTOOL planning documents for the number and position of the anchor attachments.

Connect system with anchor attachments

i The system is connected to the roof anchor with the U-rail via two base rails. It is recommended that the double roof anchors are used for connected and long rails.



i The nut (1) and washer (2) are not included in the scope of delivery and must be provided by the customer.

i

- Place the washer (4) and bracket (3) on the threaded rod of the anchor provided by the customer.
- Tighten with a suitable nut (1) and washer (2).

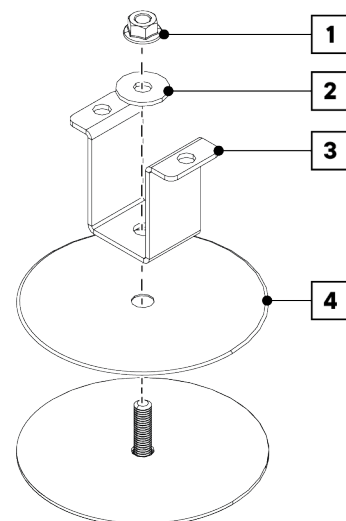

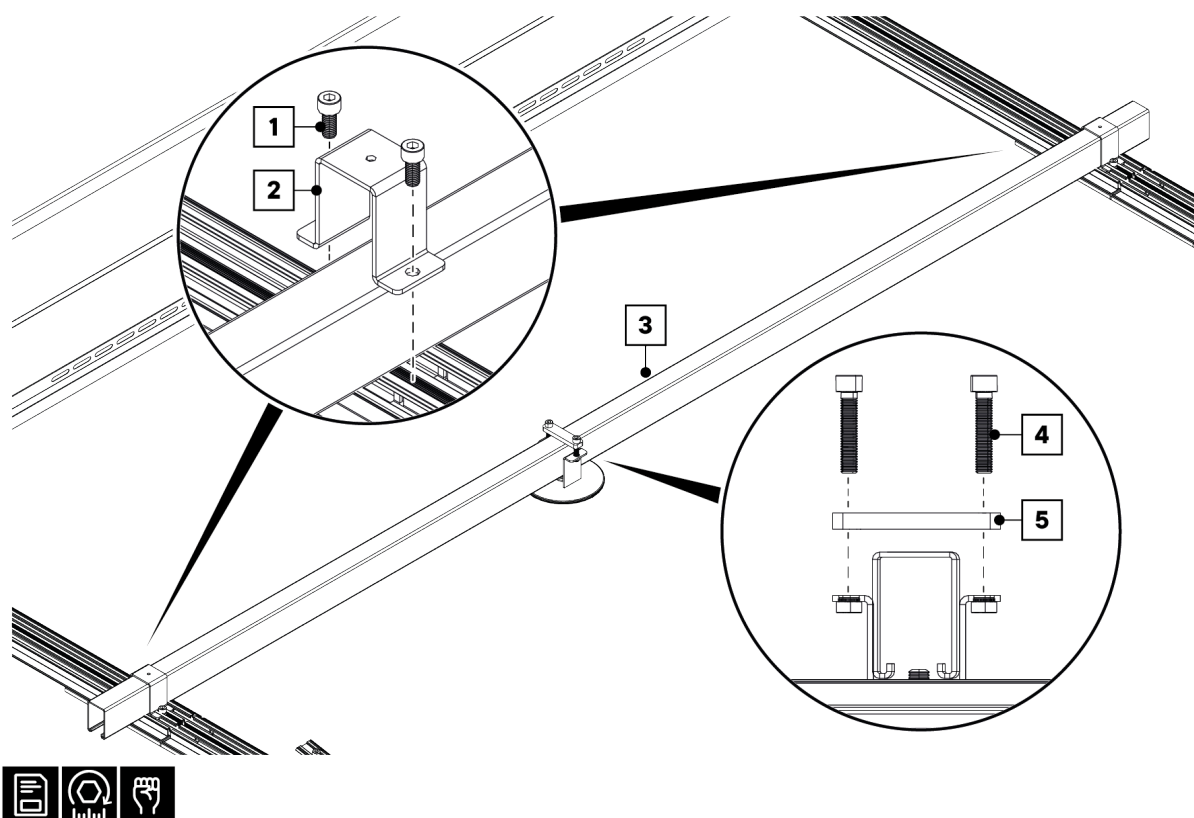

- Place the U-rail (3) so that it can be fastened with the bracket on the roof anchor and with two base rails.
- Screw the U-rail (3) to the base rails using one bracket (2) and two screws (1) in the screw channel.
- Fasten the U-rail to the roof anchor with a plate (5) and two screws (4).

MOUNT SINGLE ROOF ANCHOR ATTACHMENTS

i The anchor attachments must be provided by the customer and are not included in the scope of delivery of AEROCOMPACT.
 For the installation of the roof anchor connection, the roof anchors must be equipped by the customer with a threaded rod with a maximum size of M12 (7/16 inch). Refer to the AEROTOOL planning documents for the number and position of the anchor attachments.

Connect system with single roof anchor

i The system is connected to the base rails with single roof anchors. It is recommended that the single roof anchors are used for short rails.



i The nut (1) is not included in the scope of delivery and must be provided by the customer.

➤ Place washer (4), bracket (3) and spacer (2) on the threaded rod of the anchor provided by the customer.

i Make sure that the tab of the spacer (2) is facing outwards.

➤ Hand-tighten the components with the nut (1).

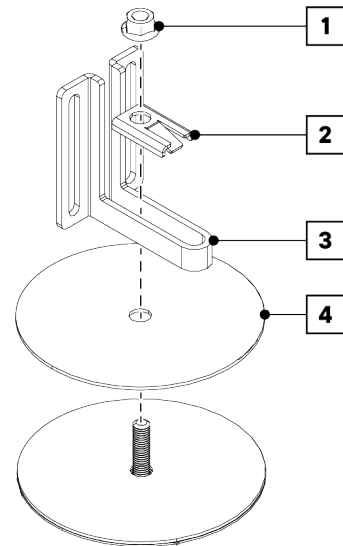

➤ For attachment to the base rails, fit a sliding nut in each of the channels next to the screw channel.

➤ Position the angle bracket (5) and the bracket (2) flush against each other.

➤ Loosely connect the angle bracket (5) and the bracket (2) to each other at the slotted holes using the combi screws (3) and nuts (1).

➤ Screw the bracket to the base rail using the combination screws and the sliding nuts.

➤ Tighten all combination screws to 15 Nm or 11 lbs.

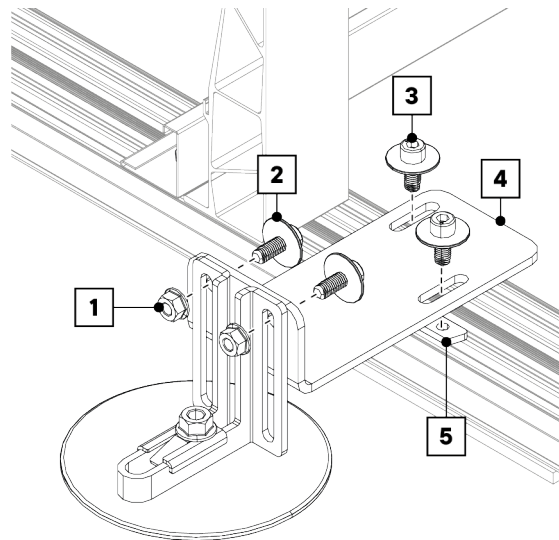

MAINTENANCE, DEMOUNTING AND DISPOSAL

MAINTENANCE

To prevent personal injury and property damage, the system must be inspected regularly by qualified personnel; an annual visual inspection is recommended for this purpose.

- Check all components of the system for damage. In case of damage, replace the affected component as soon as possible.
- Check all screw connections. Tighten loose screw connections, observing the tightening torque.
- Inspect all components for damage from weather, animals, dirt, debris, buildup, vegetation, roof penetrations, waterproofing, stability, corrosion. In case of damage, clean, repair or replace the affected component.

DISMANTLING

DISMANTLE CLAMPS (EXAMPLE)



For demounting the system, carry out the assembly steps in reverse order.

- Unscrew screw (1) on the clamp completely.
- When reusing the clamps, make sure that the O-ring (2) is not lost.

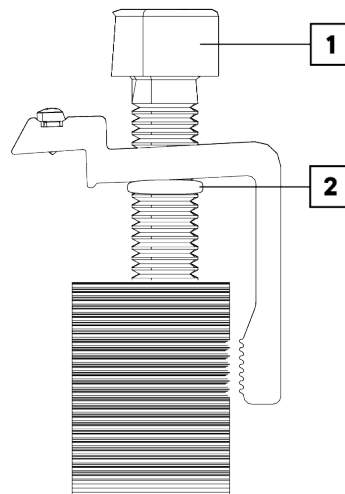

DISPOSAL

Unless a take-back or disposal agreement has been made, disassembled components should be recycled:

- Scrap metals.
- Give plastic elements for recycling.
- Dispose of remaining components sorted according to material composition.

Incorrect disposal may result in hazards to the environment. In case of doubt, obtain information on environmentally sound disposal from the local municipal authority or from specialized disposal companies.